

FUSIONMASTER® EHF350

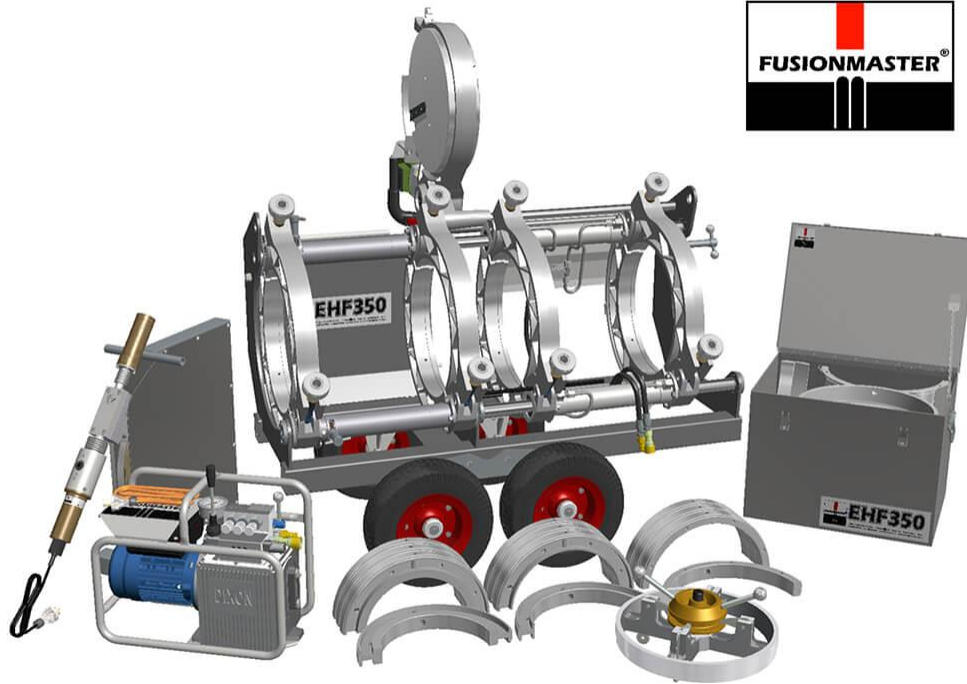

Features

- Robust, reliable and low maintenance.
- Electric hydraulic power pack enables pre-setting of 3 independent pressures.
- Unique pipe alignment mechanism overcomes pipe diameter mismatch.
- Wheels removable for trench work.
- Easy one man operation.
- Joints rapidly prepared with the powerful multi speed Facer.
- Self-centring Fittings Chuck – simple way to hold stub flanges.
- Heater provides controlled uniform surface temperature.
- Heater achieves working temperature in approximately 15 minutes.
- Replaceable non-stick Cloth system for Heater plate reduces production downtime.
- Reducing Liners available for pipe and fittings.

(The HF350 manual hydraulic pump option is also available)

SPECIFICATIONS

Component Data

Butt Machine	1230L x 690W x 1000H (mm)	178.0kg
Hydraulic Unit	0.37kw, 240 Vac 480L x 425W x 250H	27.0kg
Heater Plate	2400 W, 240 Vac	12.4kg
Facer	1150 W, 240 Vac	30.0kg
Fittings Chuck		8.6kg
Heater Stand		12.0kg
Accessory Case	530L x 400W x 320H (mm)	11.0kg

(Recommended generator for field use is 5kVA, 240V, single phase)



DIXON INDUSTRIES PTY LTD

ABN: 89 008 171 855
17 Frederick Road, Royal Park SA 5014
Tel: 61 8 8240 1555 Fax: 61 8 8240 5588
For more information visit: dixonind.com.au

FUSIONMASTER® and Dixon® are registered trademarks of Dixon Industries Pty Ltd. © Dixon Industries Pty Ltd. 2000. Revised Oct 2006